

KOMATSU

CX20 series

SPECIFICATIONS

Pneumatic Tire Lift Trucks
8,000 – 11,000 lbs. Capacity
Gas, LPG and Diesel



EPA EMISSION
COMPLIANT



KOMATSU FORKLIFT



The Forklift With Proven Ability.™

ISO 9001 CERTIFIED

TRUCK DATA

GENERAL		FG40ZT-8	FG40ZT2-8
Power Type		Gasoline	Gasoline
Operation Type		Sit-Down	Sit-Down
Capacity @ 24 in. (600 mm) load center *	lbs. (kg)	8,000 (3,630)	8,000 (3,630)
Load distance from center axle (2-stage mast)	in. (mm)	20.0 (510)	20.0 (510)
Load distance from center axle (3-stage mast)	in. (mm)	21.3 (540)	21.3 (540)
Wheelbase	in. (mm)	72.1 (1,830)	72.1 (1,830)
WEIGHT			
Service weight (includes 2-stage std. mast & forks)	lbs. (kg)	12,850 (5,830)	12,850 (5,830)
TIRE			
Tire type		Pneumatic	Pneumatic
Tire size, front		250-15-16PR (I)	250-15-16PR (I)
Tire size, rear		7.00-12-12PR (I)	7.00-12-12PR (I)
Number of wheel, front / rear	x = driven	2x / 2	2x / 2
Tread (center of tires) front / rear	in. (mm)	43.7 (1,110) / 44.1 (1,120)	43.7 (1,110) / 44.1 (1,120)
DIMENSIONS			
Tilting angle, 2-stage (FV) masts, forward / backward	deg.	6 / 12	6 / 12
Tilting angle, 3-stage (TFV) masts, forward / backward	deg.	6 / 6	6 / 6
Mast height, lowered (2-stage std. mast)	in. (mm)	92.5 (2,350)	92.5 (2,350)
Mast height, extended (2-stage std. mast) †	in. (mm)	179.0 (4,545)	179.0 (4,545)
Maximum fork height (2-stage std. mast) **	in. (mm)	131.0 (3,330)	131.0 (3,330)
Free lift height (2-stage std. mast)	in. (mm)	7.0 (180)	7.0 (180)
Height overhead guard	in. (mm)	86.2 (2,190)	86.2 (2,190)
Length to fork face (2-stage mast)	in. (mm)	115.3 (2,930)	115.3 (2,930)
Length to fork face (3-stage mast)	in. (mm)	116.6 (2,960)	116.6 (2,960)
Overall width, at drive tires	in. (mm)	52.8 (1,340)	52.8 (1,340)
Forks, thickness x width x length	in. (mm)	2.0 x 6.0 x 42.0 (50 x 150 x1,070)	2.0 x 6.0 x 42.0 (50 x 150 x1,070)
Carriage width / ITA Class	in. (mm)	46.9 (1,190) / III	46.9 (1,190) / III
Ground clearance, under mast	in. (mm)	5.5 (140)	5.5 (140)
Ground clearance, center of wheelbase	in. (mm)	6.7 (170)	6.7 (170)
Right angle stacking aisle (2-stage mast) ††	in. (mm)	120.2 (3,055)	120.2 (3,055)
Right angle stacking aisle (3-stage mast) ††	in. (mm)	121.5 (3,085)	121.5 (3,085)
Turning radius, outside	in. (mm)	100.2 (2,545)	100.2 (2,545)
PERFORMANCE			
Travel speed, forward, loaded / unloaded	mph (km/h)	11.8 (19.0) / 12.7 (20.5)	13.4 (21.5) / 14.3 (23.0)
Lifting speed, loaded / unloaded (2-stage mast)	fpm (mm/s)	114 (580) / 116 (590)	114 (580) / 116 (590)
Lifting speed, loaded / unloaded (3-stage mast)	fpm (mm/s)	110 (560) / 112 (570)	110 (560) / 112 (570)
Lowering speed, loaded / unloaded (2-stage mast)	fpm (mm/s)	102 (520) / 93 (470)	102 (520) / 93 (470)
Lowering speed, loaded / unloaded (3-stage mast)	fpm (mm/s)	98 (500) / 89 (450)	98 (500) / 89 (450)
Maximum drawbar pull, loaded	lbs. (kN)	6,830 (30.4)	8,815 (40.2)
Maximum gradeability, loaded / unloaded at 1 mph	%	32 / 21	47 / 21
Service brake, operation / control		Foot / Hydraulic	Foot / Hydraulic
Parking brake, operation / control		Hand / Mechanical	Hand / Mechanical
Steering, type		Hydrostatic, Power	Hydrostatic, Power
DRIVE			
Battery voltage / capacity (20 hour rating)	V/Ah	12 / 60	12 / 60
Engine model		TB45E	TB45E
Rated output (SAE Gross)	HP (kW) @ rpm	95 (71) @ 2400	95 (71) @ 2400
Maximum torque (SAE Gross)	lb-ft (Nm) @ rpm	203 (275) @ 1600	203 (275) @ 1600
No. of cylinder / displacement	cu. in. (cm ³)	6 / 273 (4,478)	6 / 273 (4,478)
Cylinder bore x stroke	in. (mm)	3.9 (99.5) x 3.8 (96)	3.9 (99.5) x 3.8 (96)
Fuel tank capacity	U.S. gallons (liters)	22.5 (85)	22.5 (85)
OTHER			
Relief pressure, maximum	psi (bar)	2,700 (186)	2,700 (186)
Hydraulic tank capacity	U.S. gallons (liters)	14.5 (55)	14.5 (55)
Clutch		Torque convertor	Torque convertor
Transmission		Powershift	Powershift
Air cleaner type		Cyclone	Cyclone

NOTE: Most values shown in this publication are rounded. Therefore, direct conversion between metric and English or Imperial may be slightly different from those shown. The performance of machines is affected by the condition of the vehicle and how it is equipped as well as the nature and condition of the operating area. If these specifications are critical or if your needs exceed the specifications shown here, discuss the proposed application with your authorized dealer.

FD40ZT-8	FD40ZT2-8	FG40T-8	FG40T2-8	FD40T-8	FD40T2-8
Diesel	Diesel	Gasoline	Gasoline	Diesel	Diesel
Sit-Down	Sit-Down	Sit-Down	Sit-Down	Sit-Down	Sit-Down
8,000 (3,630)	8,000 (3,630)	9,000 (4,080)	9,000 (4,080)	9,000 (4,080)	9,000 (4,080)
20.0 (510)	20.0 (510)	21.5 (545)	21.5 (545)	21.5 (545)	21.5 (545)
21.3 (540)	21.3 (540)	21.5 (545)	21.5 (545)	21.5 (545)	21.5 (545)
72.1 (1,830)	72.1 (1,830)	78.7 (2,000)	78.7 (2,000)	78.7 (2,000)	78.7 (2,000)
13,180 (5,980)	13,180 (5,980)	14,030 (6,365)	14,030 (6,365)	14,420 (6,540)	14,420 (6,540)
Pneumatic	Pneumatic	Pneumatic	Pneumatic	Pneumatic	Pneumatic
250-15-16PR(I)	250-15-16PR (I)	300-15-18PR (I)	300-15-18PR (I)	300-15-18PR (I)	300-15-18PR (I)
7.00-12-12PR(I)	7.00-12-12PR (I)	7.00-12-12PR (I)	7.00-12-12PR (I)	7.00-12-12PR (I)	7.00-12-12PR (I)
2x / 2	2x / 2	2x / 2	2x / 2	2x / 2	2x / 2
43.7 (1,110) / 44.1 (1,120)	43.7 (1,110) / 44.1 (1,120)	45.3 (1,150) / 44.1 (1,120)	45.3 (1,150) / 44.1 (1,120)	45.3 (1,150) / 44.1 (1,120)	45.3 (1,150) / 44.1 (1,120)
6 / 12	6 / 12	6 / 12	6 / 12	6 / 12	6 / 12
6 / 6	6 / 6	6 / 6	6 / 6	6 / 6	6 / 6
92.5 (2,350)	92.5 (2,350)	95.0 (2,415)	95.0 (2,415)	95.0 (2,415)	95.0 (2,415)
179.0 (4,545)	179.0 (4,545)	178.0 (4,520)	178.0 (4,520)	178.0 (4,520)	178.0 (4,520)
131.0 (3,330)	131.0 (3,330)	130.0 (3,300)	130.0 (3,300)	130.0 (3,300)	130.0 (3,300)
7.0 (180)	7.0 (180)	7.0 (180)	7.0 (180)	7.0 (180)	7.0 (180)
86.2 (2,190)	86.2 (2,190)	88.8 (2,225)	88.8 (2,225)	88.8 (2,225)	88.8 (2,225)
115.3 (2,930)	115.3 (2,930)	122.2 (3,105)	122.2 (3,105)	122.2 (3,105)	122.2 (3,105)
116.6 (2,960)	116.6 (2,960)	122.2 (3,105)	122.2 (3,105)	122.2 (3,105)	122.2 (3,105)
52.8 (1,340)	52.8 (1,340)	57.1 (1,450)	57.1 (1,450)	57.1 (1,450)	57.1 (1,450)
2.0 x 6.0 x 42.0 (50 x 150 x1,070)	2.0 x 6.0 x 42.0 (50 x 150 x1,070)	2.0 x 6.0 x 42.0 (50 x 150 x1,070)	2.0 x 6.0 x 42.0 (50 x 150 x1,070)	2.0 x 6.0 x 42.0 (50 x 150 x1,070)	2.0 x 6.0 x 42.0 (50 x 150 x1,070)
46.9 (1,190) / III	46.9 (1,190) / III	46.9 (1,190) / III	46.9 (1,190) / III	46.9 (1,190) / III	46.9 (1,190) / III
5.5 (140)	5.5 (140)	5.5 (140)	5.5 (140)	5.5 (140)	5.5 (140)
6.7 (170)	6.7 (170)	8.7 (220)	8.7 (220)	8.7 (220)	8.7 (220)
120.2 (3,055)	120.2 (3,055)	129.8 (3,295)	129.8 (3,295)	129.8 (3,295)	129.8 (3,295)
121.5 (3,085)	121.5 (3,085)	129.8 (3,295)	129.8 (3,295)	129.8 (3,295)	129.8 (3,295)
100.2 (2,545)	100.2 (2,545)	108.3 (2,750)	108.3 (2,750)	108.3 (2,750)	108.3 (2,750)
11.2 (18.0) / 12.1 (19.5)	12.4 (20.0) / 13.7 (22.0)	11.8 (19.0) / 12.7 (20.5)	14.9 (24.0) / 16.2 (26.0)	11.2 (18.0) / 12.1 (19.5)	9.3 (15.0) / 10.3 (16.5)
110 (560) / 116 (590)	110 (560) / 116 (590)	95 (480) / 97 (490)	95 (480) / 97 (490)	110 (560) / 116 (590)	110 (560) / 116 (590)
102 (520) / 108 (550)	102 (520) / 108 (550)	91 (460) / 93 (470)	91 (460) / 93 (470)	85 (430) / 91 (460)	85 (430) / 91 (460)
95 (480) / 108 (550)	95 (480) / 108 (550)	95 (480) / 85 (430)	95 (480) / 85 (430)	95 (480) / 108 (550)	95 (480) / 108 (550)
98 (500) / 89 (450)	98 (500) / 89 (450)	91 (460) / 81 (410)	91 (460) / 81 (410)	91 (460) / 81 (410)	91 (460) / 81 (410)
7,230 (32.2)	9,760 (43.4)	6,830 (30.4)	8,815 (36.3)	7,180 (31.9)	8,360 (37.2)
35 / 21	52 / 21	28 / 22	35 / 22	31 / 22	39 / 22
Foot / Hydraulic	Foot / Hydraulic	Foot / Hydraulic	Foot / Hydraulic	Foot / Hydraulic	Foot / Hydraulic
Hand / Mechanical	Hand / Mechanical	Hand / Mechanical	Hand / Mechanical	Hand / Mechanical	Hand / Mechanical
Hydrostatic, Power	Hydrostatic, Power	Hydrostatic, Power	Hydrostatic, Power	Hydrostatic, Power	Hydrostatic, Power
24 / 70	24 / 70	12 / 60	12 / 60	24 / 70	24 / 70
S6D102E	S6D102E	TB45E	TB45E	S6D102E	S6D102E
95 (71) @ 2150	95 (71) @ 2150	95 (71.0) @ 2400	95 (71.0) @ 2400	95 (71.0) @ 2150	95 (71.0) @ 2150
275 (372) @ 1000	275 (372) @ 1000	203 (275) @ 1600	203 (275) @ 1600	275 (372) @ 1000	275 (372) @ 1000
6 / 359 (5,880)	6 / 359 (5,880)	6 / 273 (4,478)	6 / 273 (4,478)	6 / 359 (5,880)	6 / 359 (5,880)
4.0 (102) x 4.7 (120)	4.0 (102) x 4.7 (120)	3.9 (99.5) x 3.8 (96)	3.9 (99.5) x 3.8 (96)	4.0 (102) x 4.7 (120)	4.0 (102) x 4.7 (120)
22.5 (85)	22.5 (85)	26.4 (100)	26.4 (100)	26.4 (100)	26.4 (100)
2,700 (186)	2,700 (186)	2,700 (186)	2,700 (186)	2,700 (186)	2,700 (186)
14.5 (55)	14.5 (55)	14.5 (55)	14.5 (55)	14.5 (55)	14.5 (55)
Torque convertor	Torque convertor	Torque convertor	Torque convertor	Torque convertor	Torque convertor
Powershift	Powershift	Powershift	Powershift	Powershift	Powershift
Cyclone	Cyclone	Cyclone	Cyclone	Cyclone	Cyclone

* Optional masts, attachments, load dimensions, tire options, tilt angles, and higher lifting heights may result in derating of the capacity. Contact your authorized dealer.

** Other mast heights available. See Mast Data chart for other standard mast heights. Contact your authorized dealer.

† Includes 48-inch (1,220 mm) high load backrest. Contact your authorized dealer.

†† Add load length and clearance. Contact your authorized dealer.

TRUCK DATA

GENERAL		FG45T-8	FG45T2-8
Power Type		Gasoline	Gasoline
Operation Type		Sit-Down	Sit-Down
Capacity @ 24 in. (600 mm) load center *	lbs. (kg)	10,000 (4,535)	10,000 (4,535)
Load distance from center axle (2-stage mast)	in. (mm)	21.5 (545)	21.5 (545)
Load distance from center axle (3-stage mast)	in. (mm)	21.5 (545)	21.5 (545)
Wheelbase	in. (mm)	78.7 (2,000)	78.7 (2,000)
WEIGHT			
Service weight (includes 2-stage std. mast & forks)	lbs. (kg)	14,730 (6,680)	14,730 (6,680)
TIRE			
Tire type		Pneumatic	Pneumatic
Tire size, front		300-15-18PR (I)	300-15-18PR (I)
Tire size, rear		7.00-12-12PR (I)	7.00-12-12PR (I)
Number of wheel, front / rear	x = driven	2x / 2	2x / 2
Tread (center of tires) front / rear	in. (mm)	45.3 (1,150) / 44.1 (1,120)	45.3 (1,150) / 44.1 (1,120)
DIMENSIONS			
Tilting angle, 2-stage (FV) masts, forward / backward	deg.	6 / 12	6 / 12
Tilting angle, 3-stage (TFV) masts, forward / backward	deg.	6 / 6	6 / 6
Mast height, lowered (2-stage std. mast)	in. (mm)	95.0 (2,415)	95.0 (2,415)
Mast height, extended (2-stage std. mast) †	in. (mm)	178.0 (4,520)	178.0 (4,520)
Maximum fork height (2-stage std. mast) **	in. (mm)	130.0 (3,300)	130.0 (3,300)
Free lift height (2-stage std. mast)	in. (mm)	7.0 (180)	7.0 (180)
Height overhead guard	in. (mm)	88.8 (2,225)	88.8 (2,225)
Length to fork face (2-stage mast)	in. (mm)	124.0 (3,150)	124.0 (3,150)
Length to fork face (3-stage mast)	in. (mm)	124.0 (3,150)	124.0 (3,150)
Overall width, at drive tires	in. (mm)	57.1 (1,450)	57.1 (1,450)
Forks, thickness x width x length	in. (mm)	2.0 x 6.0 x 42.0 (50 x 150 x 1,070)	2.0 x 6.0 x 42.0 (50 x 150 x 1,070)
Carriage width / ITA Class	in. (mm)	46.9 (1,190) / III	46.9 (1,190) / III
Ground clearance, under mast	in. (mm)	5.5 (140)	5.5 (140)
Ground clearance, center of wheelbase	in. (mm)	8.7 (220)	8.7 (220)
Right angle stacking aisle (2-stage mast) ††	in. (mm)	130.9 (3,325)	130.9 (3,325)
Right angle stacking aisle (3-stage mast) ††	in. (mm)	130.9 (3,325)	130.9 (3,325)
Turning radius, outside	in. (mm)	109.5 (2,780)	109.5 (2,780)
PERFORMANCE			
Travel speed, forward, loaded / unloaded	mph (km/h)	11.2 (18.0) / 12.1 (19.5)	14.6 (23.5) / 16.2 (26.0)
Lifting speed, loaded / unloaded (2-stage mast)	fpm (mm/s)	95 (480) / 97 (490)	95 (480) / 97 (490)
Lifting speed, loaded / unloaded (3-stage mast)	fpm (mm/s)	91 (460) / 93 (470)	91 (460) / 93 (470)
Lowering speed, loaded / unloaded (2-stage mast)	fpm (mm/s)	95 (480) / 85 (430)	95 (480) / 85 (430)
Lowering speed, loaded / unloaded (3-stage mast)	fpm (mm/s)	91 (460) / 81 (410)	91 (460) / 81 (410)
Maximum drawbar pull, loaded	lbs. (kN)	6,610 (29.4)	8,165 (36.3)
Maximum gradeability, loaded / unloaded at 1 mph	%	26 / 21	32 / 21
Service brake, operation / control		Foot / Hydraulic	Foot / Hydraulic
Parking brake, operation / control		Hand / Mechanical	Hand / Mechanical
Steering, type		Hydrostatic, Power	Hydrostatic, Power
DRIVE			
Battery voltage / capacity (20 hour rating)	V/Ah	12 / 60	12 / 60
Engine model		TB45E	TB45E
Rated output (SAE Gross)	HP (kW) @ rpm	95 (71) @ 2400	95 (71) @ 2400
Maximum torque (SAE Gross)	lb-ft (Nm) @ rpm	203 (275) @ 1600	203 (275) @ 1600
No. of cylinder / displacement	cu. in. (cm ³)	6 / 273 (4,478)	6 / 273 (4,478)
Cylinder bore x stroke	in. (mm)	3.9 (99.5) x 3.8 (96)	3.9 (99.5) x 3.8 (96)
Fuel tank capacity	U.S. gallons (liters)	26.4 (100)	26.4 (100)
OTHER			
Relief pressure, maximum	psi (bar)	2,700 (186)	2,700 (186)
Hydraulic tank capacity	U.S. gallons (liters)	14.5 (55)	14.5 (55)
Clutch		Torque converter	Torque converter
Transmission		Powershift	Powershift
Air cleaner type		Cyclone	Cyclone

NOTE: Most values shown in this publication are rounded. Therefore, direct conversion between metric and English or Imperial may be slightly different from those shown. The performance of machines is affected by the condition of the vehicle and how it is equipped as well as the nature and condition of the operating area. If these specifications are critical or if your needs exceed the specifications shown here, discuss the proposed application with your authorized dealer.

* Optional masts, attachments, load dimensions, tire options, tilt angles, and higher lifting heights may result in derating of the capacity. Contact your authorized dealer.

** Other mast heights available. See Mast Data chart for other standard mast heights. Contact your authorized dealer.

	FD45T-8	FD45T2-8
	Diesel	Diesel
	Sit-Down	Sit-Down
	10,000 (4,535)	10,000 (4,535)
	21.5 (545)	21.5 (545)
	21.5 (545)	21.5 (545)
	78.7 (2,000)	78.7 (2,000)
	15,110 (6,855)	15,110 (6,855)
	Pneumatic	Pneumatic
	300-15-18PR (I)	300-15-18PR (I)
	7.00-12-12PR (I)	7.00-12-12PR (I)
	2x / 2	2x / 2
	45.3 (1,150) / 44.1 (1,120)	45.3 (1,150) / 44.1 (1,120)
	6 / 12	6 / 12
	6 / 6	6 / 6
	95.0 (2,415)	95.0 (2,415)
	178.0 (4,520)	178.0 (4,520)
	130.0 (3,300)	130.0 (3,300)
	7.0 (180)	7.0 (180)
	88.8 (2,225)	88.8 (2,225)
	124.0 (3,150)	124.0 (3,150)
	124.0 (3,150)	124.0 (3,150)
	57.1 (1,450)	57.1 (1,450)
	2.0 x 6.0 x 42.0 (50 x 150 x 1,070)	2.0 x 6.0 x 42.0 (50 x 150 x 1,070)
	46.9 (1,190) / III	46.9 (1,190) / III
	5.5 (140)	5.5 (140)
	8.7 (220)	8.7 (220)
	130.9 (3,325)	130.9 (3,325)
	130.9 (3,325)	130.9 (3,325)
	109.5 (2,780)	109.5 (2,780)
	10.9 (17.5) / 11.8 (19.0)	13.7 (22.0) / 15.2 (24.5)
	91 (460) / 95 (480)	91 (460) / 95 (480)
	85 (430) / 91 (460)	85 (430) / 91 (460)
	89 (450) / 89 (450)	89 (450) / 89 (450)
	91 (460) / 81 (410)	91 (460) / 81 (410)
	6,890 (30.6)	8,440 (37.5)
	29 / 21	35 / 21
	Foot / Hydraulic	Foot / Hydraulic
	Hand / Mechanical	Hand / Mechanical
	Hydrostatic, Power	Hydrostatic, Power
	24 / 70	24 / 70
	S6D102E	S6D102E
	95 (71) @ 2150	95 (71) @ 2150
	275 (372) @ 1000	275 (372) @ 1000
	6 / 359 (5,880)	6 / 359 (5,880)
	4.0 (102) x 4.7 (120)	4.0 (102) x 4.7 (120)
	26.4 (100)	26.4 (100)
	2,700 (186)	2,700 (186)
	14.5 (55)	14.5 (55)
	Torque converter	Torque converter
	Powershift	Powershift
	Cyclone	Cyclone

† Includes 48-inch (1,220 mm) high load backrest. Contact your authorized dealer.

†† Add load length and clearance. Contact your authorized dealer.

FG50AT2-8	FD50AT2-8
Gasoline	Diesel
Sit-Down	Sit-Down
11,000 (5,000)	11,000 (5,000)
21.7 (550)	21.7 (550)
21.7 (550)	21.7 (550)
78.7 (2,000)	78.7 (2,000)

16,060 (7,285)	16,440 (7,455)
----------------	----------------

Pneumatic	Pneumatic
300-15-18PR (I)	300-15-18PR (I)
7.00 x 12 x 16PR (I)	7.00 x 12 x 16PR (I)
2x / 2	2x / 2
45.3 (1,150) / 44.1 (1,120)	45.3 (1,150) / 44.1 (1,120)

6 / 12	6 / 12
6 / 6	6 / 6
98.5 (2,500)	98.5 (2,500)
178.0 (4,520)	178.0 (4,520)
130.0 (3,300)	130.0 (3,300)
7.0 (180)	7.0 (180)
88.8 (2,255)	88.8 (2,255)
124.2 (3,155)	124.2 (3,155)
124.2 (3,155)	124.2 (3,155)
57.1 (1,450)	57.1 (1,450)
2.2 x 6.0 x 42.0 (55 x 150 x 1,070)	2.2 x 6.0 x 42.0 (55 x 150 x 1,070)
46.9 (1,190) / IV	46.9 (1,190) / IV
5.5 (140)	5.5 (140)
8.7 (220)	8.7 (220)
131.1 (3,330)	131.1 (3,330)
131.1 (3,330)	131.1 (3,330)
109.5 (2,780)	109.5 (2,780)

13.1 (21.0) / 14.9 (24.0)	13.1 (21.0) / 14.9 (24.0)
95 (480) / 97 (490)	79 (400) / 95 (480)
91 (460) / 93 (470)	79 (400) / 89 (450)
89 (450) / 89 (450)	89 (450) / 89 (450)
95 (480) / 83 (420)	95 (480) / 83 (420)
8,165 (36.3)	8,370 (37.2)
29.5 / 21.0	32.0 / 27.0
Foot / Hydraulic	Foot / Hydraulic
Hand / Mechanical	Hand / Mechanical
Hydrostatic, Power	Hydrostatic, Power

12 / 60	24 / 70
TB45E	S6D102E
95 (71) @ 2400	95 (71) @ 2150
203 (275) @ 1600	275 (372) @ 1000
6 / 273 (4,478)	6 / 359 (5,880)
3.9 (99.5) x 3.8 (96)	4.0 (102) x 4.7 (120)
26.4 (100)	26.4 (100)

2,700 (186)	2,700 (186)
14.5 (55)	14.5 (55)
Torque Converter	Torque Converter
Powershift	Powershift
Cyclone	Cyclone

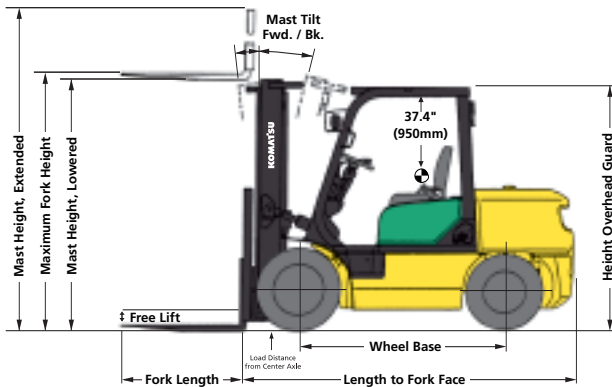
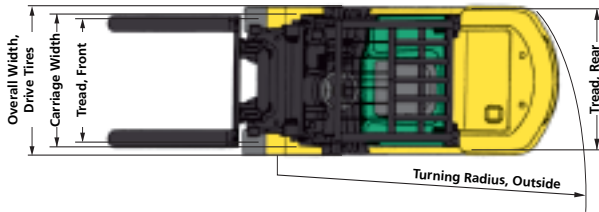

CALL YOUR LOCAL KOMATSU FORKLIFT DEALER FOR MAST & ATTACHMENT OPTIONS.



Komatsu “Proven Ability”

is Komatsu’s ability to eclipse the competition by taking the complicated and making it simple. We strive to provide innovative solutions using the technologies of tomorrow—today.

SPECIAL FEATURES

- The TB45E gasoline and Komatsu S6D102E diesel industrial engines deliver exceptional power, emission control, and reliable operation for enhanced productivity and fuel efficiency.
- Suspension compartment (SC) greatly reduces operator fatigue by isolating the compartment from engine and traveling vibrations.
- Swing up engine bonnet and lift out floor plate provide quick access for daily checks and maintenance.
- Open perforated steps and assist hand grip make entry and exit easier.
- Dash display provides easy to read information to the operator and maintenance personnel.

STANDARD EQUIPMENT

- Dash Display – Fuel, Water Temperature and Hour Meter Gauges
- Drawbar Pin
- Electronic Ignition; Anti-Restart Ignition Switch
- Engine Key Stop (Diesel Units)
- Engine Oil Pressure and Charge Warning Lamps
- Fully Hydrostatic Power Steering (FHPS)
- Headlights – OHG mounted
- High Air Intake in OHG
- Horn
- “Komfort” Seat and Operator Restraint System with Lap Belts
- Load Backrest

- Overhead Guard
- Sedimeter (Diesel Units)
- Tilttable Steering Column
- Torque Converter Oil Cooler
- Turn Signal, Back-up, Stop and Tail Lights

OPTIONAL EQUIPMENT

- Additional Length Forks
- Attachments
- Auxiliary Hydraulic Valve
- Internal Hydraulic Hosing
- Warning Devices – Audible
- Warning Devices – Visual

Contact your authorized dealer for other options.

TECHNICAL DATA

ENGINE

TB45E gasoline/LPG 6 cylinder in-line, 4.5 liter with ECCS (Engine Concentrated Control System) engine to meet the next generation of low emission standards. This new low RPM high torque industrial engine offers a higher level of engineering excellence through exceptional emission controls, acceleration, performance, reliability, and serviceability.

- Three engine choices: gasoline with multi-port fuel injection, or LPG with single-port (throttle body) fuel injection, or dual-fuel operation easily switching between fuels with a flip of the switch. All trucks are equipped with a 3-way catalytic converter.
- All engines utilize an ECCS that continuously monitors engine component data from the accelerator pedal, throttle position, mass-air-flow, water temperature, fuel pressure, and heated oxygen sensor, for increased sensitivity, reliable cold starts, and smooth performance throughout the operating range. An electronic governor is used for rev-limit protection.
- Crankshaft and Camshaft position sensors are used for optimum ignition and fuel injection timing. Each cylinder has its own ignition coil for precision spark generation.
- Temperature sensor prevents overheating during high temperature operation by automatically limiting engine speed until the coolant temperature returns to within normal operating range, if the coolant temperature exceeds a specific temperature, the engine will shut down automatically. When the engine exceeds normal operating temperature a dash displayed warning light is also illuminated.
- Aluminum-alloy head with larger intake/exhaust valves and advanced design combustion chamber.
- All engine main (seven) and connecting rod bearings are micro-grooved to provide smooth operation and reduce wear.
- Additionally, the low noise level provides comfort to the operator while driving the truck.

S6D102E diesel 6 cylinder in-line, 5.9 liter 4 stroke cycle turbo-charged direct injection engine that produces high performance and excellent fuel economy. The Komatsu S6D102E diesel engine delivers the power and efficiency to get the job done quickly and cost-effectively while meeting emission requirements.

- The starting system of quick glow spark (QGS) ensures a quicker and reliable start in all climate conditions.

FUEL SYSTEM

Gasoline, LPG, dual-fuel, or diesel system. Integral fuel (gasoline or diesel) tank.

- Easy servicing gasoline four function electric fuel pump with, a fuel level gauge, fuel pressure regulator, and fuel filter.
- Easy servicing diesel fuel system includes clean-out hole, and full flow fuel filter with water separator.
- Liquid propane gasoline (LPG) fuel is available with (optional) 33 lb. or 43 lb. tank.

COOLING SYSTEM

Large capacity, highly efficient aluminum radiator with integral torque converter and hydraulic oil cooler.

- Easy access reservoir tank for checking or adding of coolant.
- Plastic bladed cooling fan with unequal pitched blades for additional noise reduction and efficiency.

ELECTRICAL SYSTEM

Standard operator conveniences that are optional on most, such as a complete light package, horn and hour meter, are standard on Komatsu.

- 12-volt (gasoline or LPG), and 24-volt (diesel) electrical systems.
- 50-amp hour (35 amp hour diesel); alternator with built in I.C. regulator.

- Key lock anti-restart ignition switch.
- Starter motor: enclosed with watertight connectors and planetary gear reduction for higher torque at lower current draw.
- Dash displayed fuel level and water temperature gauges.
- Warning lights for engine oil pressure, battery charging, brake fluid level, ECCS monitor and operation fault indicator.
- ECCS - SST (Service Support Tool) connector interface for rapid engine diagnostics. (non diesel)

HYDRAULIC SYSTEM

The hydraulic system features an integral reservoir, rebuildable direct drive gear pump, and fully filtered system.

- Large capacity reservoir and radiator cooling keeps the hydraulic fluid at an efficient operating temperature.
- Load sensing valve in the hydraulic circuit halts the flow of oil to the power steering system when steering wheel is idle.

FRAME

All welded assembly made of heavy gauge steel with integral hydraulic and fuel tanks.

- Flange type drive axle mounting and heavy-duty engine mounts improve product reliability.
- Front cross member integral part of frame for increased structural integrity.
- Open perforated step on both sides of truck for easy entry and exit.

DRIVE AXLE

Heavy duty cast steel axle housing supports weight of truck and load while full-floating axle shafts transmit torque without bearing wear.

- Flange mounting on frame members reduces load deflection increasing stability and capacity.

TRANSMISSION

The "Powershift" transmission is a single speed forward and reverse transmission and is built to exacting specifications. It is specially designed for use in industrial lift trucks. The two speed "Powershift" transmission is also available for certain models.

- Column mounted electric shift directional control lever provides effortless shifting for forward and reverse.
- Optimized torque converter stall ratio, improve torque, and gradeability without sacrificing travel speeds.
- Modulating control valve absorbs shock during sudden acceleration or travel direction change. This function improves plugging capability and prolongs transmission life.
- In-line 100 mesh and 25 micron transmission oil filter and oil cooler are equipped as standard to ensure trouble free operation.
- Inching pedal reduces the fluid pressure to the clutch pack – to creep the truck or have high engine RPM's to perform faster hydraulic functions.
- Rebuildable clutch pack can be removed and re-built without removing the transmission.

BRAKES

Hydraulic assisted service brakes with master cylinder booster are self-adjusting and self-centering.

- High friction, large diameter asbestos-free brake linings are housed in the drive axle.
- Enlarged brake covers prevent dirt and water from entering the linings.
- Mechanical parking brake is actuated from adjustable toggle handle on dash allowing for more legroom in the operator's compartment.

STEER AXLE

Standard on demand, Fully Hydrostatic Power Steering (FHPS).

- Heavy-duty fabricated steel axle with integral double-acting, double-ended power steer cylinder eliminates drag links and tie rods.
- All wheel hub bearings and king pins are easily accessible for lubrication and service.

MAST, CARRIAGE, LBR & FORKS

High visibility mast assembly with 6-roller carriage available in 2-Stage Free-View and 2-Stage or 3-Stage Full Free-View type.

- Sealed bearings for reduced maintenance with standard side thrust rollers on carriage.
- Equipped with ITA Class III or Class IV carriage bars for mounting forks or a variety of attachments.
- 48-inch load backrest is standard for increased load control and operator safety.
- Single and double function internal hosing is available for operating attachments.

OPERATOR'S COMPARTMENT

A unique full-floating Suspension Compartment (SC) designed to isolate the operator from fatigue producing vibration.

- Orthopedically designed 'Komfort' seat with built-in lumbar support, retractable seat belt, lateral restraint system, and 6" (150mm) of seat travel is standard.
- Hydraulic control levers have easy-to-read international symbols on the contoured grips and are within easy reach of operator.
- Tilting steering console, with infinite adjustment through tilt range positions instrument panel in full view of operator at all times.
- Floor mounted automotive-type pedals with large ribbed pads for comfort and safe operation. Accelerator pedal is mounted on a Teflon roller mechanism to reduce operator effort.
- Full width floor mat provides large non-slip surface, reduces noise, vibration, and heat.
- Large open steps and convenient assist handgrip provides easy entry and exit for the operator.
- Separate inching and braking pedals provide positive control while reducing wear on the drive train.
- Trucks come standard with an integral headlight/turn indicator control. Turn indicator has automatic return to neutral.
- The 3-piece overhead guard is full width and offers excellent visibility for stacking high loads.

SERVICEABILITY

Excellent access to engine compartment, transmission, and radiator areas can be achieved without tools. Making daily checks and maintenance easier.

- The gas cylinder-assisted, one-piece all metal engine compartment cover lifts easily and is insulated to reduce noise and heat.
- Cover also features a single latch for locking down and an open cover catch to prevent cover from coming down while in open position.
- Bottom corner of cover is angled to allow more access into engine compartment for scheduled maintenance and service.

COMPLIANCE & APPROVALS

Meets or exceeds American National Standards Institute, ASME B56.1 - Part III Safety Standards for Powered Industrial Trucks.

Classified by Underwriters Laboratories, Inc. as to fire and electric shock hazard only. Contact your authorized dealer for application specifics.

Meets or Exceeds EPA Emission standards 40 CFR. Komatsu Forklift U.S.A., Inc. is an ISO 9001 certified facility headquartered in Covington, Georgia.

KOMATSU®

Komatsu Forklift U.S.A., Inc.

14481 Lochridge Boulevard, Covington, GA 30014

Telephone: 770-787-5100 Fax: 770-385-6003

1-800-821-9365

www.komatsuforkliftusa.com

YOUR AUTHORIZED DEALER OF KOMATSU FORKLIFTS