

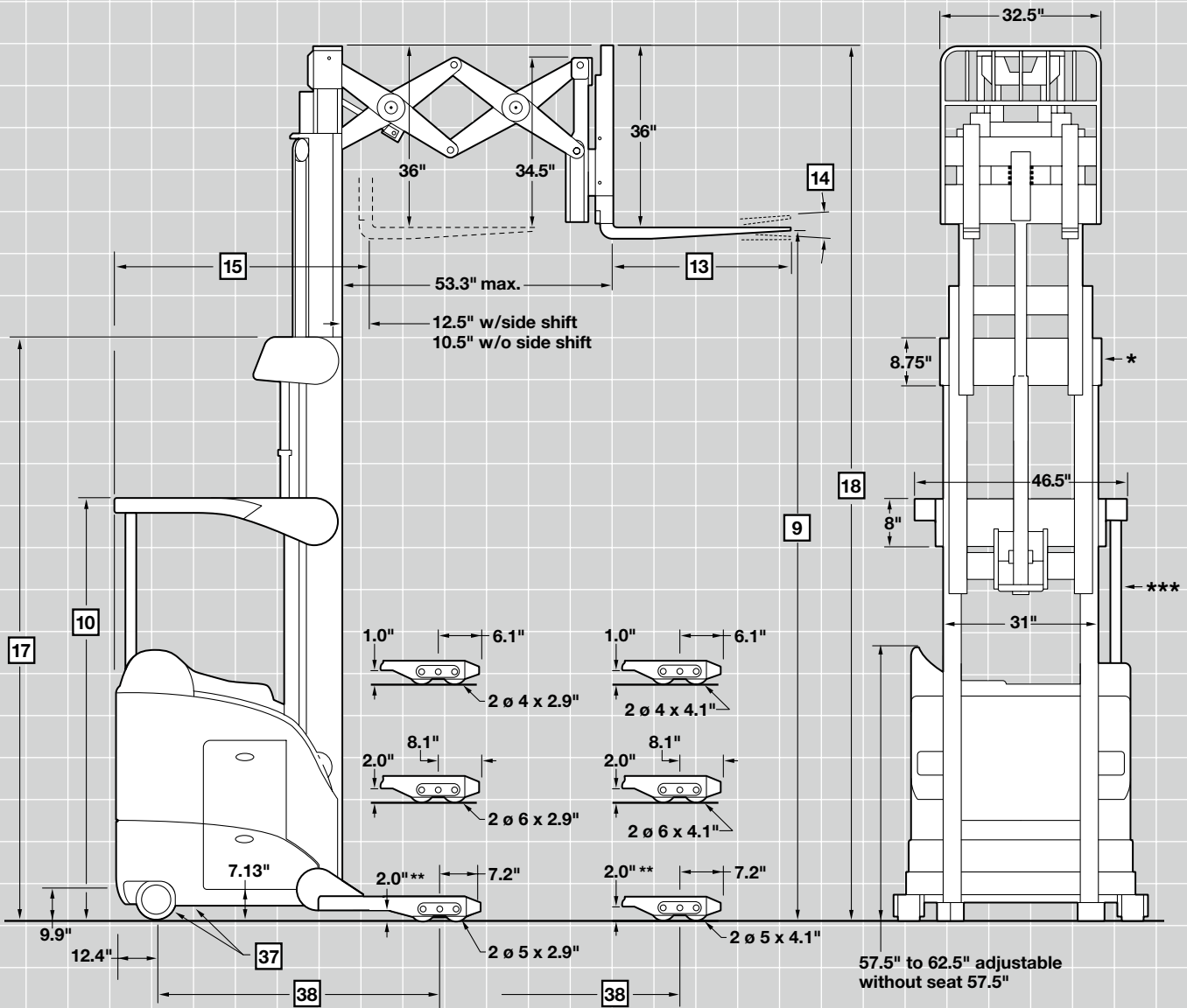

RD 5700 S Series

Profile Sheet

RD 5700 S Series

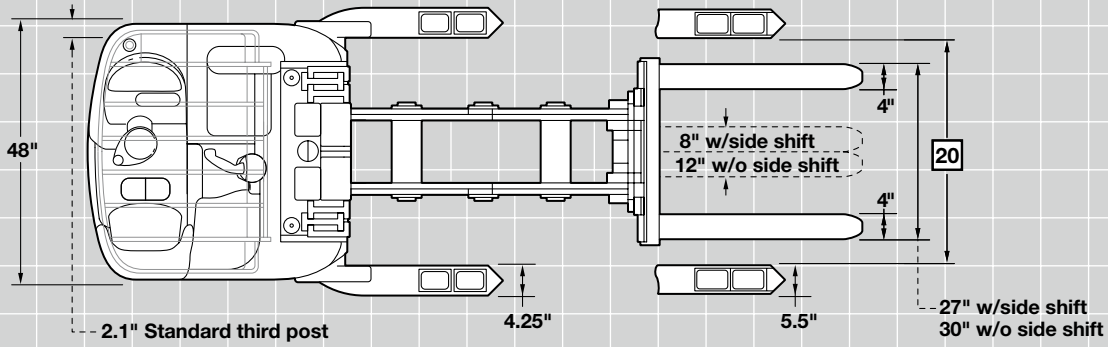

* Top tie bar width – 33" for 240" or 270" lift. 35" for 300" and above.
 ** 1.0" on lift heights above 321"
 *** Standard third post location, refer to dimension in top view.

RD 5700 S Series

General Information	1	Manufacturer		Crown Equipment Corporation
	2	Model		RD 5795S
	3	Load Capacity*	Max	lb 3000
	4	Load Center	Fork Face to Load CG	in 24
	5	Power		36 Volts
	6	Operator Type	Reach	Sit/Stand
	7	Tire Type	Load/Caster/Drive	Poly/Poly/Poly
	8	Wheels (x = driven)	Load/Power Unit	4/2 (1x)
Dimensions		Mast Type	Hi-Visibility	TT
	9	Lift Height		in See Mast Chart
	10	Guard Height		in See Mast Chart
	13	Forks	Standard L x W x T	in 36 x 4 x 1.5
			Optional Lengths	in 30, 39, 42, 45, 48
	14	Carriage	Tilt F°/B°	degree 3 / 4
	15	Headlength**	Comp't "C"	in 60.06
			Comp't "D"	in 61.81
			Comp't "E"	in 64.43 / 69.18†
	17	Overall Collapsed Height		in See Mast Chart
18	Overall Extended Height		in See Mast Chart	
20	Inside Straddle Width	In 1" increments	in 34 - 50	
Chassis	37	Tires	Size - Drive/Caster	in 13 x 5.5 / 8.5 x 2.7 x (2)
	38	Wheelbase (Standard Wheel)	Comp't "C"	in 61.32
			Comp't "D"	in 63.07
			Comp't "E"	in 65.70 / 70.45†
	39	Suspension	Drive	Articulated
			Caster	Articulated, Swivel
42	Brakes	Drive	Elec Release / Mech Applied	
		Caster	Electronically Applied	
		Parking	Elec Release / Mech Applied	
Battery		Battery Removal		Drive Side
	45	Type		Lead Acid
	46	Min Weight/Max Amp	Comp't "C"	lb/amp 2000 / 930
			Comp't "D"	lb/amp 2280 / 1085
			Comp't "E" ≤ 400"	lb/amp 2600 / 1240
			Comp't "E" 401-442"	lb/amp 2800 / 1240
		Max Battery Size	Comp't "C"	in 16.25x38.69x31
Comp't "D"			in 18.00x38.69x31	
Comp't "E"			in 20.75x38.69x31	

* Contact factory. Capacity may be subject to derating at height.

** Add 2" with optional sideshift.

† 442" Lift Height

RD 5700 S Series

		TT							
Mast	9	Lift Height	198"	210"	240"	270"	300"	321"	
		Free Lift*	53	59	71	83	95	104	
	10	Guard Height	89	95	95	95	95	95	
	17	Overall Collapsed Height	89	95	107	119	131	140	
	18	Overall Extended Height*	234	246	276	306	336	357	
		Minimum Straddle OD	42	42	42	42	42	42	
Weight	Truck Weight w/o Battery		Battery Compartment						
	RD 5795S	"C"	lb	6329	6439	6752	7041	7548	7725
		"D"	lb	6379	6489	6802	7091	7598	7775
		"E"	lb	6434	6544	6857	7146	7653	7830

		TT						
Mast	9	Lift Height	341"	366"	400"	421"	442"	
		Free Lift*	113	124	136	142	154	
	10	Guard Height	95	95	95	95	95	
	17	Overall Collapsed Height	149	160	172	178	190	
	18	Overall Extended Height*	377	402	436	457	478	
		Minimum Straddle OD	49	50	53	53	53	
Weight	Truck Weight w/o Battery		Battery Compartment					
	RD 5795S	"C"	lb	na	na	na	na	na
		"D"	lb	8136	na	na	na	na
		"E"	lb	8191	8407	8641	9109	9473

*With load backrest.
Above 321", 6" high load wheel standard.



Crown Equipment Corporation
New Bremen, Ohio 45869 USA
Tel 419-629-2311
Fax 419-629-3796
crown.com

You can count on Crown to build lift trucks designed for safe operation, but that's only part of the safety equation. Crown encourages safe operating practices through ongoing operator training, safety-focused supervision, maintenance and a safe working environment. Go to crown.com and view our safety section to learn more.

Because Crown is continually improving its products, specifications are subject to change without notice.

Crown, the Crown logo, the color beige, the Momentum mark, Access 1 2 3, InfoPoint, InfoLink, ThermoAssist, OnTrac and Work Assist are trademarks of Crown Equipment Corporation.

Copyright 2009 Crown Equipment Corporation
SF18384-1 7/09
Printed in U.S.A.