



With Rotational Control



With Rotational Control



Without Rotational Control



Without Rotational Control



Precise positioning. Perfect pad placement.

APPLICATIONS

Automatically allows driver to quickly and precisely pick up and place rolls. By aligning pads with the roll, the Rotational Control helps assure proper pad-to-roll contact and keeps pad edges from digging into the roll. By aligning the roll with the ground or supporting rolls, Electronic Rotational Control eliminates roll edge damage. Won't push bilge rolls away from the clamp due to pad misalignment, and keeps rolls aimed straight during staging at the press or unwinder.

FEATURES

- Rotation stops at 90°, 180° and 360°.
- Driver can override rotation stop, or rotation stop times out after three seconds, allowing normal control by driver.
- Each stop point is accurate within 1°.
- Each stop point has a deceleration ramp, extending life of rotation mechanism.
- Stop points are electronically controlled; no mechanical hardware to wear out.
- All stops are adjustable.
- Rotation is prevented at each stop by rotation gear mechanism.
- Stops can be easily removed for operations that don't require them.

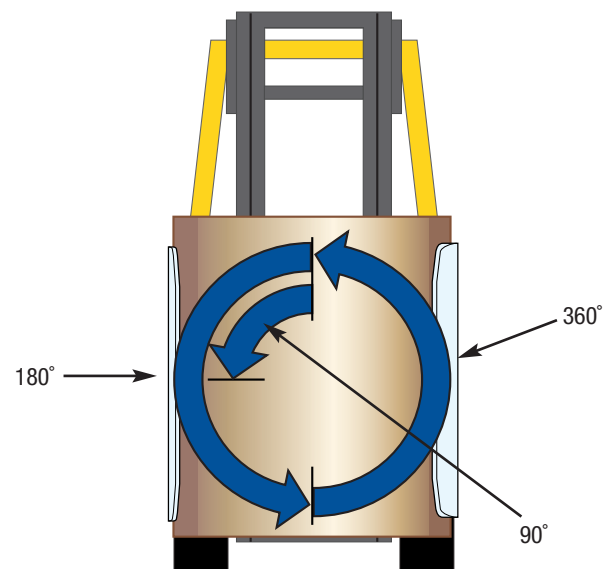

Standard rotational stops shown.

Increases productivity by helping the driver quickly and precisely pick up and place rolls, thereby reducing product damage.

FIELD INSTALLATION KIT

- Includes:** New motor valve
Wire harnesses
Stop ramps
Electronic junction box
Tap for tapping holes

Requires a power supply ordered separately.

Model	Catalog Order No.
12 Volt—std. single drive	228705
24 Volt—std. single drive	228706
36 Volt—std. single drive	228707
48 Volt—std. single drive	228708

POWER SUPPLY

- Includes:** Conduit
Coiled Cord Assembly
Power Wire Harness
Pigtail Adapter
Normally Open Switch
Hardware for Fastening to Mast and Carriage

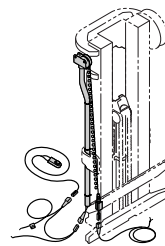

For use only on roll clamps with electronic rotational control.

Mast Maximum Fork Height	Conductors	Catalog Order No.
MFH		
188"	2	6001137
240"	2	228719

OTHER RECOMMENDED DAMAGE REDUCTION OPTIONS

Clamp Force Indicator



Measuring device that shows the clamp force applied to the load. Used for clamp pressure calibration with systems using pressure relief valves.

(Paper Roll Clamp version shown.)

Light Bar Kit and Multi-Setting Relief Valve



The light bar shows the pressure setting in use when installed with the Multi-Setting Pressure Relief Valve.

AFC

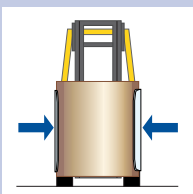

AFC (Adaptive Force Control) is a computer-controlled clamping system that automatically controls the clamp force in proportion to the load weight.

Adjustable Bumper



Ensures that smaller rolls are correctly positioned between the pads – not trapped in the arms.

Swing Frame



Swing Frame models offer you the optimum in roll handling speed and capability. The lateral 'swing' or sideshifting function adds an extra dimension of flexibility to the clamp's breakout and tight stacking capabilities.

Split-Arm



Allows secure handling of two stacked rolls of different diameters. Patented hydraulic circuit allows clamping of one roll with minimum top arm movement.

Tilt Control

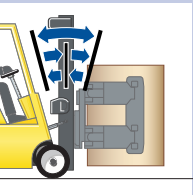

Automatically controls the angle of the mast and attachment, aligning pad with the load.

Two-Way Tilt Control

Load Cushion™



Hoist System Accumulator that absorbs shocks and reduces the clamp force required to handle the load. Available in one-pint and one-quart sizes.