



A simple way to pull marble and granite slabs from closed-top containers.

APPLICATIONS

A safe and efficient method of handling marble, granite and other stone slabs, the Marble Handler is designed to support the load as it is pulled out of a closed-top container. The load can then be picked up with an overhead crane.

FEATURES

- Traversing carriage
- Thin arm pad profile
- Internal relief valve
- Carriage compatibility

OPTIONS

- Special arm size
- Special arm configuration
- Special opening range



Now, a lift truck attachment designed to handle marble, granite and other stone slabs.

MARBLE HANDLER

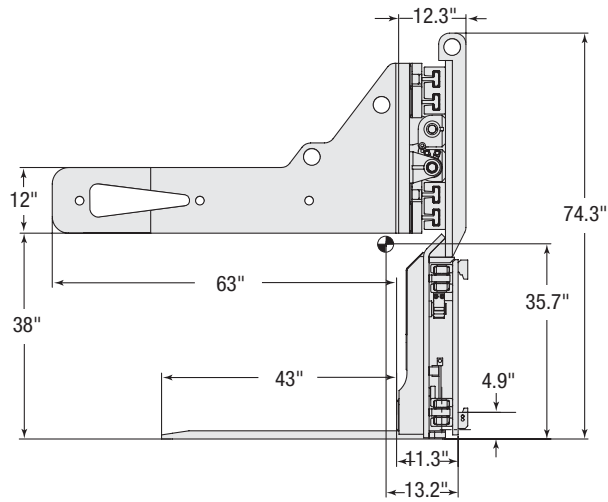
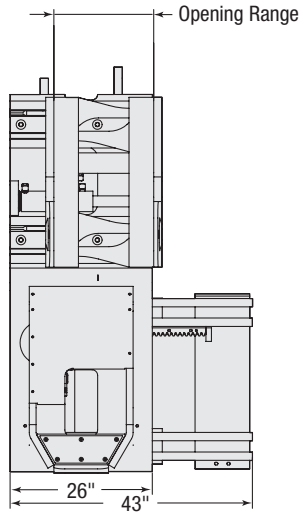

Capacity @ 24" (600 mm) Load Center		Opening Range	Catalog Order No.	Mtg. Class	Weight		Effective Thickness	Horizontal Ctr. of Gravity	Vertical Ctr. of Gravity	Frame Width	Min. Truck Carriage Width
lbs	kg	ITI			lbs	kg	ET	HCG	VCG		
7,000	3,180	10"-26"	70D-MHT-14C	IV	2,900	1,320	11.3"	13.2"	35.7"	43"	41"

- ▶ Designed for unloading bundles of marble and granite. Arms are for stabilizing only. Bottom foot is for raising the end of the load. This is not a clamping or carrying attachment.
- ▶ A chain or strap is used to secure the load when pulling the bundles from the trailer. Chain or strap not included.

HYDRAULIC FUNCTIONS

Hydraulic Functions	Truck Aux. Valves Required
2	2

HYDRAULIC FLOW & PRESSURE

Min. Flow	Recommended Flow	Max. Flow	Max. Pressure
7 GPM	12 GPM	15 GPM	2300 PSI/159 bar

MOUNTING CLASS INFORMATION

Mounting Class	Truck Capacity
IV	10,001-17,500 lbs

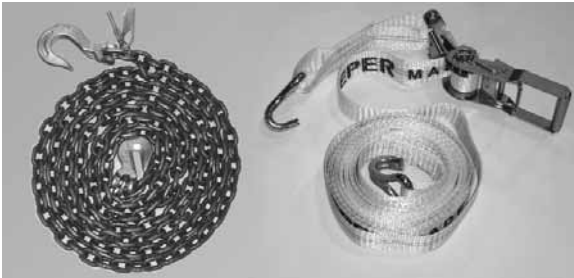

- Use a chain with a minimum 3/8 inch diameter and a minimum 7,000 lbs. vertical lift capacity.
- OR
- Use a strap with a minimum break strength of 10,000 lbs. and a minimum load limit of 3,333 lbs.

- ▶ A video of proper marble handler operation can be viewed at www.cascorp.com/products/marblehandler. To order a video on CD, see the Video Order Form at www.cascorp.com.