



## Designed for fast single- and dual-cube handling.

### APPLICATIONS

Handles single or dual concrete cubes safely and efficiently using a variety of fork lengths and spacing to fit any cube handling application. Single sideshifting models allow accurate positioning on single unit loads. Dual independent sideshifting models offer accurate fork positioning and greater stability, so operators can pick dual cubes separately, then sideshift them together for stable transportation.

### FEATURES

- Utilizes our proven high-visibility sideshifters, which are no-weld mounted, allowing for easy re-positioning
- “Over-center” sideshift standard for easy truck loading
- Heavy-duty structural frame
- Protected bearing segments with easily accessible grease fittings
- Heavy-duty cylinders with case-hardened and chromed rods for long life in outdoor operations
- Self-cleaning cylinder rods
- Floating-eye forks

### MODELS

#### *Single Sideshifting Block Handler*

- 6, 8 or 12 forks
- 10,000 pound capacity
- 15,000 pound capacity

#### *Dual Sideshifting Block Handler*

- 12 or 16 forks
- 10,000 pound capacity
- 15,000 pound capacity



*Increases productivity by providing efficient single- and dual-cube handling.*

# BLOCK HANDLER

## Single

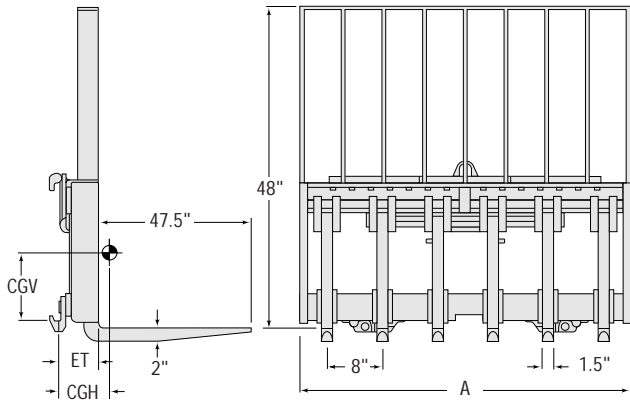

## Dual

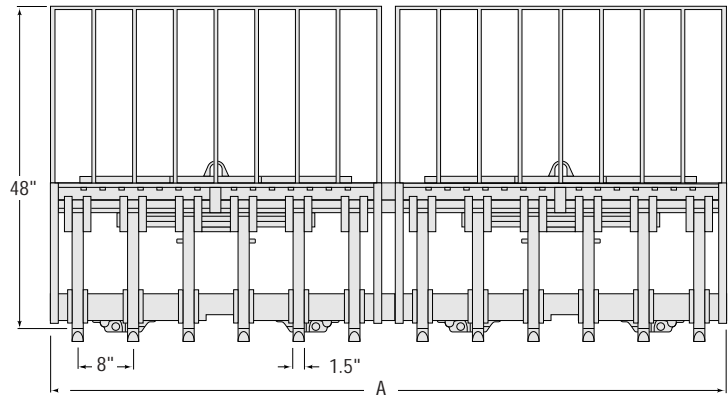

Capacity Lbs. @ 24" Load Center	Catalog Order No.	Truck/ Sideshift Mounting Class	Weight (Lbs.)	Number of Forks	Effective Thickness ET	Horizontal Center of Gravity CGH	Vertical Center of Gravity CGV	Carriage Width A	Total Sideshift	Minimum Truck Carriage Width
<b>Single Block Handlers</b>										
9,000	100E-BSS-48	III	1,095	6	5.0"	7.5"	9.2"	48"	8"	41"
10,000	100E-BSS-60	III	1,410	8	5.0"	7.8"	9.2"	60"	8"	48"
10,000	100E-BSS-96	III	1,720	12	5.0"	8.0"	9.3"	96"	8"	82"
9,000	150D-BSS-48	IV	1,235	6	5.3"	8.3"	13.0"	48"	12"	41"
12,000	150D-BSS-60	IV	1,555	8	5.3"	7.4"	12.9"	60"	12"	48"
15,000	150D-BSS-96	IV	2,100	12	6.0"	9.2"	8.5"	96"	12"	82"
<b>Dual Block Handlers</b> ①④										
10,000	100E-BDS-96	IV ③	2,645	12	8.0"	8.3"	9.6"	96"	12"	62"
10,000	100E-BDS-120	IV ③	3,420	16	8.0"	8.2"	10.2"	120"	12"	80"
15,000	150D-BDS-96	IV ③	3,370	12	8.6"	8.1"	13.1"	96"	12"	62"
15,000	150D-BDS-120	②	4,235	16	8.6"	8.1"	13.1"	120"	12"	80"

- ① False carriage is included with model.
- ② Integral or pin mount. Integral carriages do not include load rollers or attaching hardware.
- ③ Integral mounting available for higher net truck capacity.
- ④ Dual Block Handlers require two installation kits.
- Consult Cascade for any required modification.

## OPTIONS

- Nonstandard frame width
- Variable fork length and spacing
- Variable type of fork mounting (floating eye standard)
- Load backrests (48" standard)
- Integral or pin mounting
- Quick-Disconnect mounting kit

## INSTALLATION KIT

Model	Catalog Order Number
100E	205826
150D	209555

## HYDRAULIC FLOW AND PRESSURE

Model	Minimum	Recommended	Maximum	Max. Pressure
Class III	1 GPM	4 GPM	5 GPM	3,500 PSI
Class IV	1 GPM	6 GPM	12 GPM	3,000 PSI

## HYDRAULIC FUNCTIONS

Model	Hydraulic Functions	Truck Auxiliary Valves Required
Single	1	1
Double	2	2

## MOUNTING CLASS INFORMATION

Mounting Class	Truck Capacity
III	6,000-10,000 lbs.
IV	10,001-17,500 lbs.