



*For bin inverting
and dumping
versatility.*



Hold bins securely while rotating.

APPLICATIONS

Lightweight Bin Retainer for the agricultural market. Retains plastic and wooden bins during rotation.

FEATURES

- Easy mounting and removal
- Front bar chamfered for easy bin pick-up
- Wide lower hook for stability
- Heavy duty upper fork hook
- Adjustable in 3/4" increments

OPTIONS

- Increased vertical range
- Shorter or longer horizontal arm



BIN RETAINER

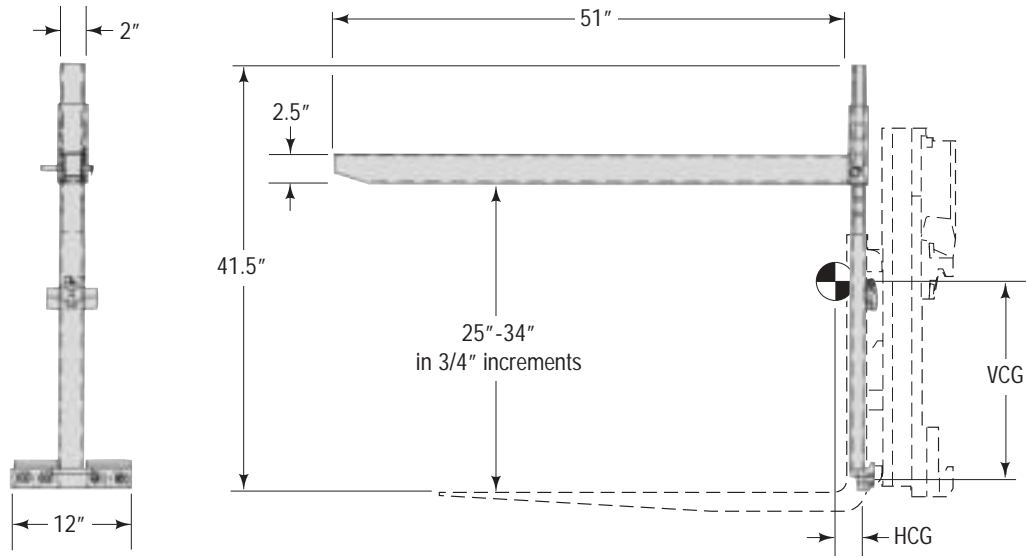

Capacity @ 24" (610 mm) Load Center ^①		Catalog Order No.	Mtg. Class	Mtg. Angle	Min. Truck Carriage Width	Weight		Effective Thickness ^③	Horizontal Ctr. of Gravity HCG	Vertical Ctr. of Gravity VCG
lbs	kg					lbs	kg			
400	180	40D-BRF-01A	II	N/A	N/A	62	28	2.0	11.2	20.6

NOTES

- ① Specifications for Bin Retainer are shown with horizontal bar located at midrange.