

The ability to clamp, rotate, and push your product.

APPLICATIONS

Cascade's Inverta Push may be used in nearly every operation that ships unit loads of bags or cartons, such as fertilizer, grain, cement, mail, sugar, canned goods, boxed goods, glass and plastic.

- **Retrieving your pallets with an Inverta Push**

The Inverta Push enables you to warehouse your products on in-house, 'captive' pallets. For shipping, the Inverta Push places the load on a slip-sheet, customer pallet or directly on the transit vehicle floor, then retrieves your pallet. Your pallets need never leave the warehouse.

- **Retaining your expensive pallets in-house eliminates the need to dead-head pallets after unloading at the destination.**

The receiver has no return costs to pay and you can reduce your total pallet inventory. The Inverta Push consists of two opposing sets of forks for clamping, an automatically sequenced stabilizer arm on the side with forks, an integral sideshifter, a rotator to invert or rotate the load and a push plate for push-off load deposit.

HOW IT WORKS

- 1 Bottom forks are inserted in pallet. Load is clamped against upper forks. Side stabilizer engages load to secure it for rotation.
- 2 As truck moves to load-out point, Inverta Push turns 180° so pallet is on top of load. Slipsheet or customer pallet (if used) is now on bottom.
- 3 Forks lift pallet off load. Operator pushes off and backs away simultaneously.

Retain your pallets in-house, and reduce your total pallet inventory.

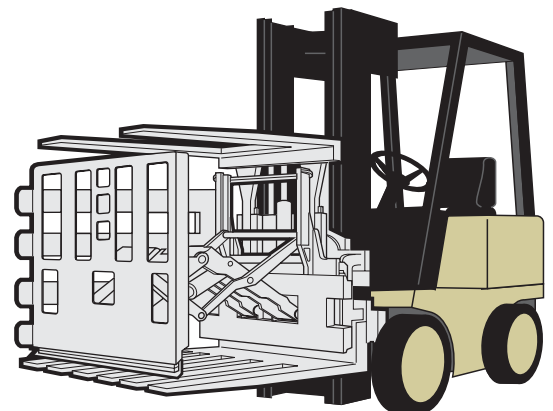

Inverta Push™

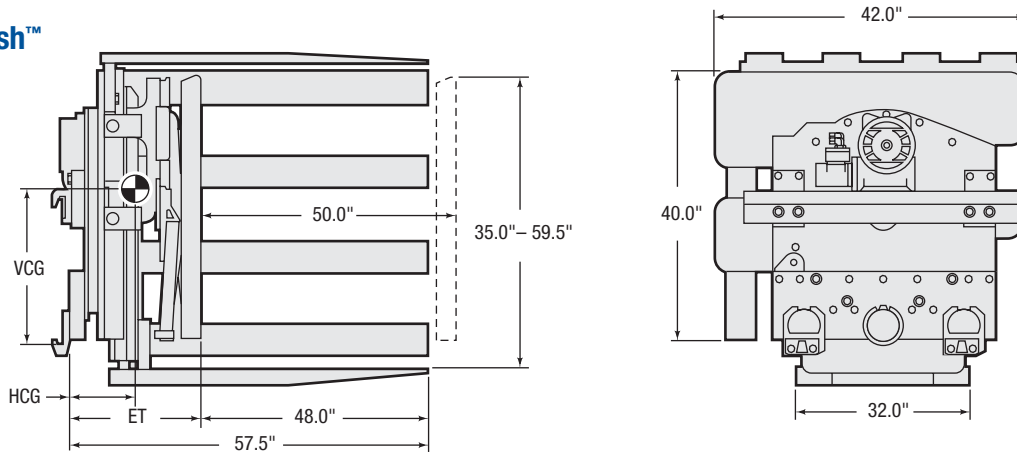

Capacity @ 24" (600 mm) Load Center		Arm Length	Catalog Order No.	Mfg. Class	Mfg. Angle	Hydraulic Functions ①	Weight		Effective Thickness ET	Horizontal Ctr. of Gravity HCG	Vertical Ctr. of Gravity VCG
lbs	kg						lbs	kg			
4,000	1,815	48"	45E-IVP	III	0°	4	3,000	1,362	19.5"	14.8"	18.0"

Notes

- ① This base unit is equipped with solenoids and may be controlled with either one or two auxiliary valves on the truck. **IMPORTANT:** Solenoid voltage must match truck voltage. Please specify truck voltage when ordering.

Options

- Load push/pull mechanism
- Various opening and closing ranges
- Various types, sizes and spreads of arms
- Class II and IV mounting

Hydraulic Flow

Minimum	Recommended	Maximum	Maximum Pressure
5 GPM	7 GPM	10 GPM	2,300 PSI

Hydraulic Functions

Hydraulic Functions ②	Truck Auxiliary Valves Required
4	1

Installation Kit

Catalog Order No.
685559